

STRUCTURE AND SUPPORTS

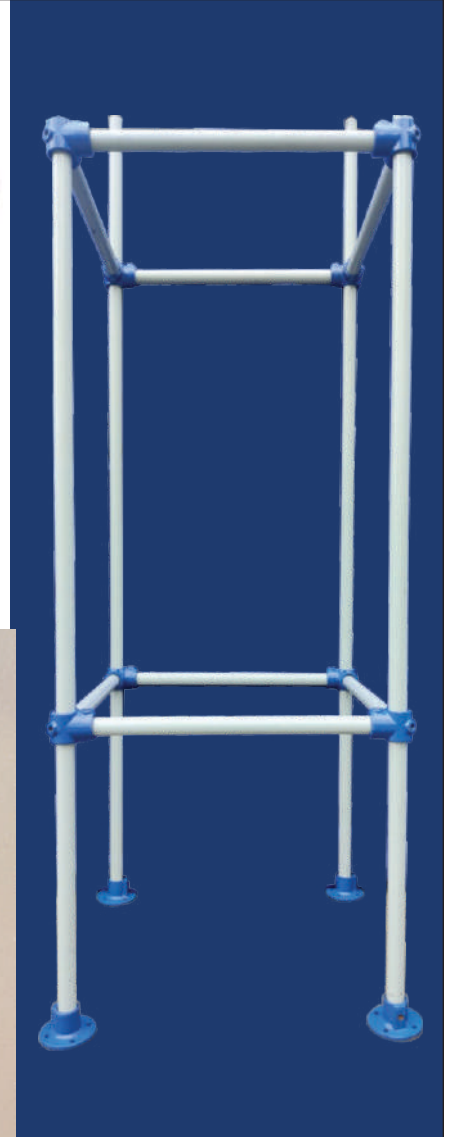
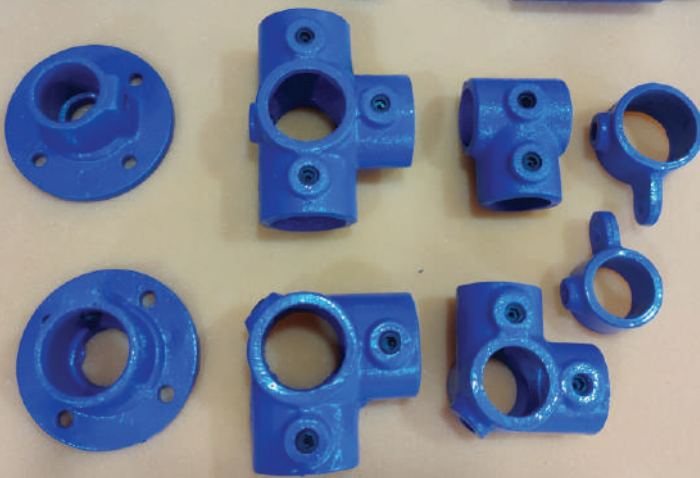

Glass plants are normally supported in a tubular structure formed of galvanised steel tubes or mild steel with epoxy coated or stainless steel 304 & 316. This type of structure is proved robust and flexible over many years.

STRUCTURE AND SUPPORTS

SUPPORT OF COLUMN

Glass plants and pipeline should be supported correctly. To prevent inducing undesirable stresses in the glass, support should be rigid. When supported, glass should be in compression.

Generally, glass plant and equipment are supported in a rectangular tubular structure. This structure is formed of galvanised mild steel tubing with the cast iron fittings which are described in this catalogue. This type of structure provides enough flexibility for future modifications and is strong enough to support a glass unit.

Following rules should be followed while supporting a glass unit in a tubular structure.

1. The structure must be rigid. To give lateral support it must be braced back to the nearest wall or any rigid feature.
2. All glass columns are build up from a fixed point on which whole weight of the column should be taken.
3. With change in temperature, glass column and tubular structure expands at different rate. Therefore glass unit must be free for vertical movement above the fixed point. Hence, above the fixed point, guides supports should be used to give lateral support.

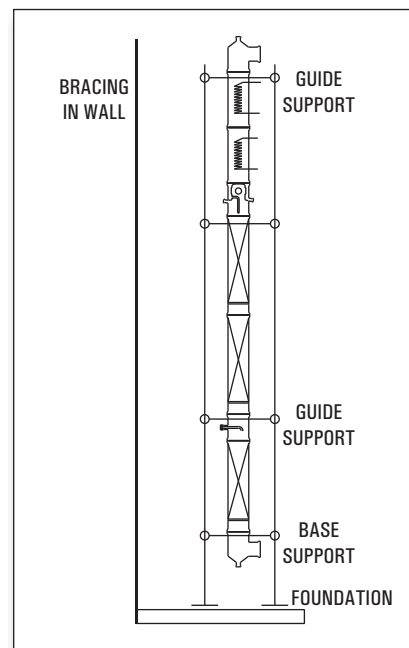

STRUCTURE TUBES, GALVANISED

For forming the structure, "B" class galvanised tubes, Mild Steel with Epoxy Coated, Stainless Steel 304 & 316 are used in size of 1/2", 1", 1.1/4", 1.1/2" and 2". Cut tubes are available in required length to form a standard size structure. Cut tubes are provided with rubber plug at both the ends.

Tube size

NB Inches	NB mm	External Diameter
1/2"	15	19.5
1"	25	32.5
1.1/4"	30	41.5
1.1/2"	40	48.3
2"	50	60.3

Available cut lengths

Structure Dimension	NB (mm)				
	15*	25*	30*	40*	50*
2500	-	2500	-	-	-
3000	-	3000	3000	-	-
3500	-	3500	3500	-	-
4000	-	-	4000	-	-
6000	-	6000	6000	6000	6000

For Vertical installation

2500	-	2500	-	-	-
3000	-	3000	3000	-	-
3500	-	3500	3500	-	-
4000	-	-	4000	-	-
6000	-	6000	6000	6000	6000

For Frames

400	-	365	355	345	335
500	-	465	455	445	435
600	-	565	555	545	535
800	-	765	755	745	735
1000	-	965	955	945	935
1200	-	1165	1155	1145	1135
1500	-	1465	1455	1445	1435

For Support

400	450	450	450
500	550	550	550
600	650	650	650
800	850	850	850
1000	1050	1050	1050
1200	1250	1250	1250

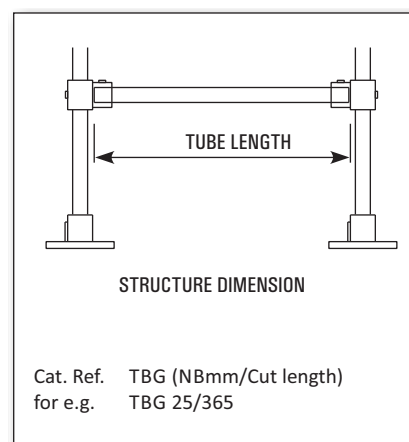

STRUCTURE AND SUPPORTS

STRUCTURE FITTINGS

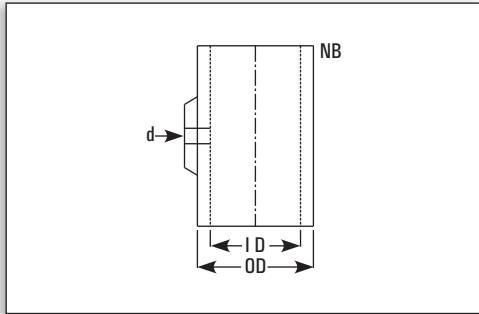

Following structure fittings are available to use with galvanised tubes in order to form a tubular structure for a glass plant. These fittings are made of cast iron. Also available in Stainless Steel 304 & 316 and are suitable to the galvanised tubes described earlier.

These slidable fittings are provided with grub screws to fix it at required position on a galvanised tube.

These fittings are specially made to construct a tubular structure which provides enough flexibility for future modifications without involving any hammering and welding.

STRUCTURE FITTINGS - GENERAL DATA

NB	TUBE DIA	ID	OD	d
25	32.5	35	45	1/2"
30	42.5	45	55	1/2"
40	48.3	51	61	1/2"
50	60.3	63	73	1/2"

STRUCTURE FITTINGS - BASE

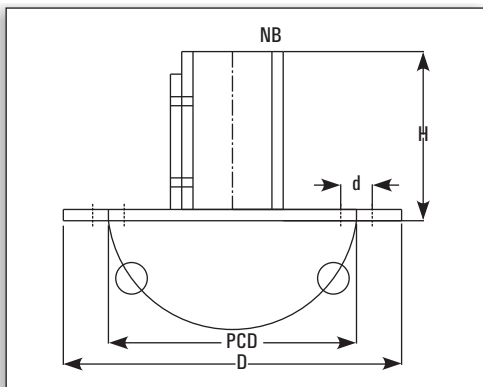

These are to be used with vertical tubes. Holes are provided for foundation.

Cat.Ref.	NB	D	H	PCD	d ϕ
BS25*	25	150	75	110	4 x 14 ϕ
BS30*	30	150	75	110	4 x 14 ϕ
BS40	40	150	75	110	4 x 14 ϕ
BS50	50	175	75	125	4 x 14 ϕ

STRUCTURE FITTINGS - COUPLER

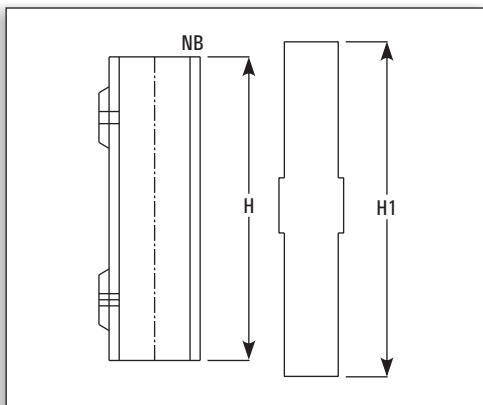

These are generally used to couple the vertical tubes where more length is require.

Cat.Ref.	NB	H	H1
CL25	25	150	200
CL30	30	150	200
CL40	40	150	200
CL50	50	150	200

STRUCTURE FITTINGS - BEND

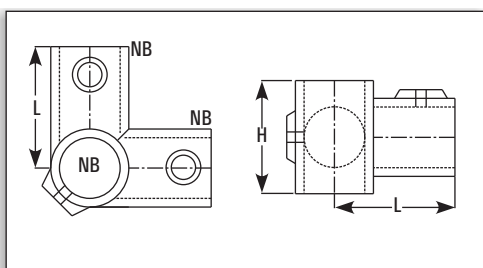

These are used to build frames on vertical tubes.

Cat.Ref.	NB	H	L
BN 25*	25	55	55
BN30*	30	65	70
BN40	40	70	80
BN50	50	85	95

* marked items are available fast.

STRUCTURE AND SUPPORTS

STRUCTURE FITTINGS - TEE

Cat.Ref.	NB	H	L
T25*	25	50	55
T30*	30	65	70
T40	40	70	80
T50	50	85	95

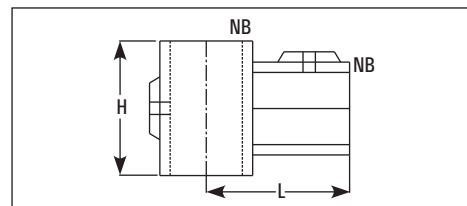

STRUCTURE FITTINGS - DOUBLE BEND

Cat.Ref.	NB	H	L
DBN 25	25	55	55
DBN30	30	65	70
DBN40	40	70	80
DBN50	50	85	95

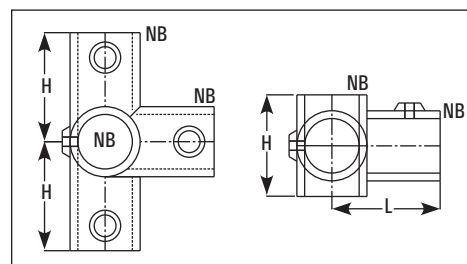

STRUCTURE FITTINGS - DOUBLE TEE

Cat.Ref.	NB	H	L
DT25	25	50	55
DT30	30	65	70
DT40	40	70	80
DT50	50	85	95

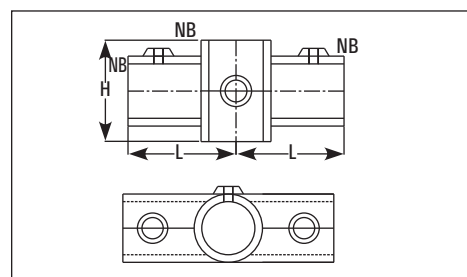

STRUCTURE FITTINGS - EQUAL BRACKET

Cat.Ref.	NB	H	L	L1
EBT25*	25	45	65	50
EBT30*	30	55	80	55
EBT40	40	60	85	60
EBT50	50	70	95	60

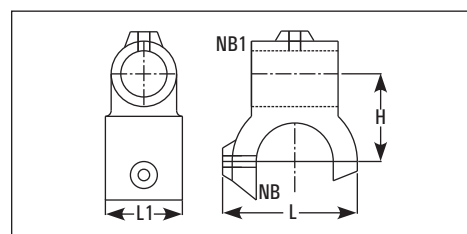

STRUCTURE FITTINGS - UNEQUAL BRACKET

Cat.Ref.	NB	NB1	H	L	L1
UBT25/15*	25	15	40	65	50
UBT30/15*	30	15	50	75	60
UBT40/25	40	25	55	85	60
UBT50/25	50	25	60	95	65

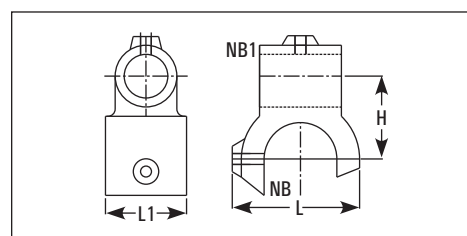

STRUCTURE FITTINGS - CROSS

Cat.Ref.	NB	H	L
X25	25	50	45
X30	30	65	55
X40	40	65	70
X50	50	65	85

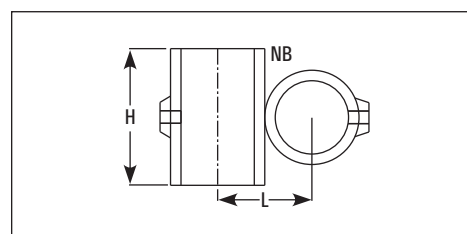

STRUCTURE AND SUPPORTS

STRUCTURE FITTINGS - SUPPORT

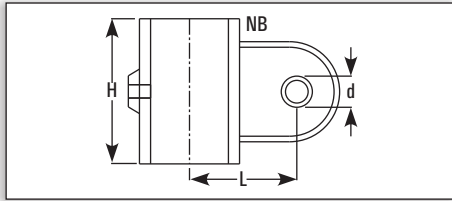

Cat.Ref.	NB	h	L	d
SPT15*	15	30	35	13
SPT25*	25	40	50	13
SPT30*	30	45	57	13
SPT40	40	50	62	13
SPT50	50	55	67	13

STRUCTURE FITTINGS - PLUGS

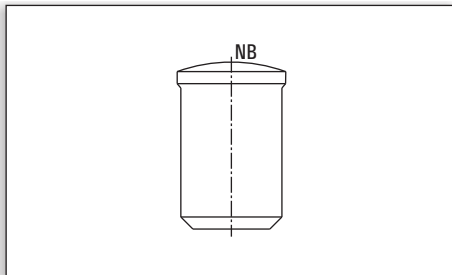

These are used to plug the open ends of galvanised tubes.

Cat. Ref.	NB
PLUG15*	15
PLUG25*	25
PLUG30*	30
PLUG40	40
PLUG59	50

STRUCTURE FITTINGS - STUDS

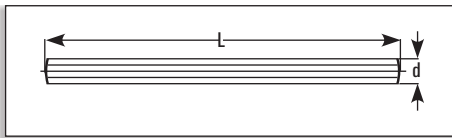

These are used as screwed rods with supports

Cat. Ref.	d	L
STUD5/16-150*	5/16"	150
STUD3/8-150*	3/8"	150
STUD1/2-200	1/2"	200

STRUCTURE DIMENSIONS

FOR COLUMNS

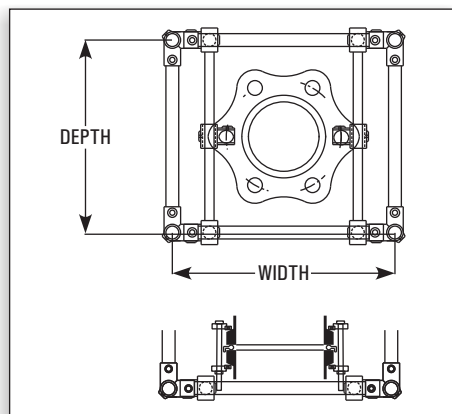

DN	Recommended tube size NB (mm)	Minimum Structure size Depth X Width
80	25	500 x 500
100	25	500 x 500
150	25,30	600 x 600
225	30	800 x 800
300	30	800 x 800
400	30	1000 x 1000
450	30,40	1000 x 1000
600	40,50	1200 x 1200

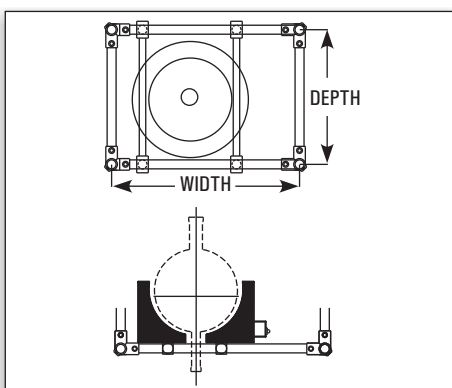

FOR VESSELS (IN HEATING MENTLES)

Size (Litres)	Recommended tube size NB (mm)	Minimum Structure size Depth X Width
20	25	400 x 600
50	25	600 x 800
100	25,30	800 x 800
200	30	800 x 1000

* marked items are available fast.

STRUCTURE AND SUPPORTS

FOR VESSELS (IN HEATING BATHS)

Size (Litres)	Recommended tube size NB (mm)	Minimum Structure size Depth X Width
20	25	500 x 600
50	25	600 x 800
100	25,30	800 x 1000
200	30	800 x 1200

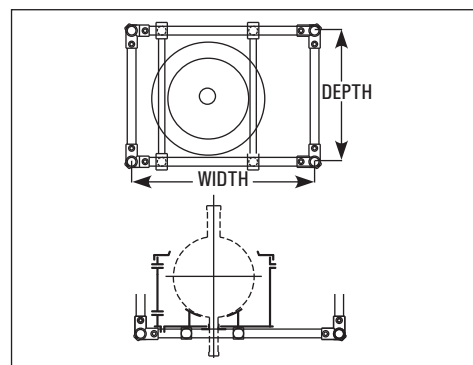

FOR VESSELS (IN VESSEL HOLDERS)

Size (Litres)	Recommended tube size NB (mm)	Minimum Structure size Depth X Width
20	25	500 x 600
50	25	600 x 800
100	25,30	1000 x 1000
200	30	1000 x 1000

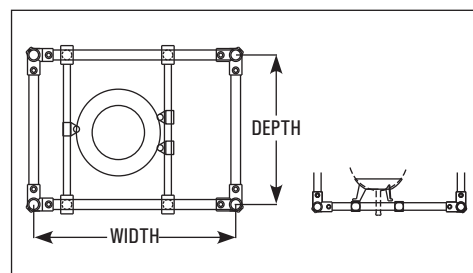

COLUMN BASE SUPPORT FRAMES

These channel frames are used as fixed support in erection of columns. These are supplied with full threaded jacking rods and U bolts.

Cat.Ref.	PCD	L1	L	H
FCSH225	310	1000	800	75
FCSH300	395	1000	800	75
FCSH400	495	1200	1000	75
FCSH450	585	1200	1000	100
FCSH600	710	1400	1200	100

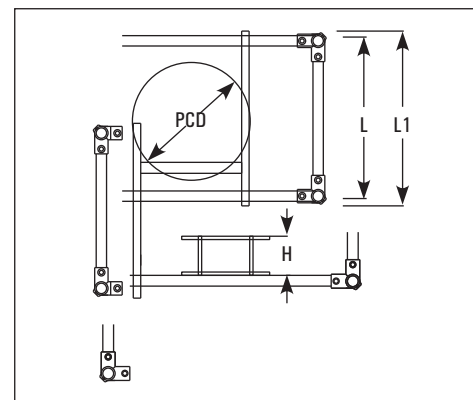

STRUCTURE AND SUPPORTS

GROUTING OF BASE

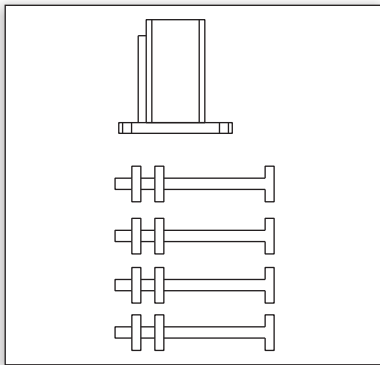

1. Take one Cast Iron BASE and four foundation Bolts, each with 2 nuts.

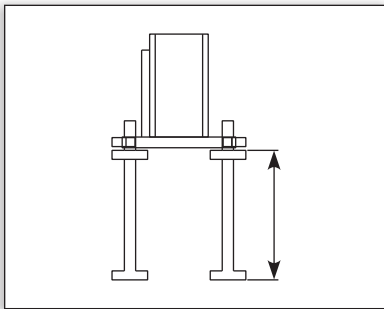

2. Fit the bolts in BASE so that base is raised upto 150mm from head of bolts.

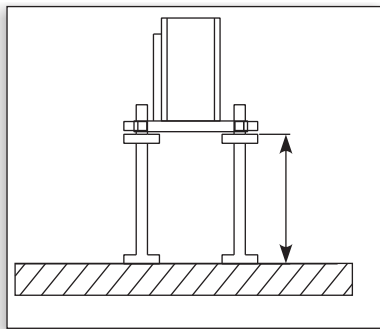

3. Put this assembly on the floor and prepare a rough surface for proper bonding of grouting.

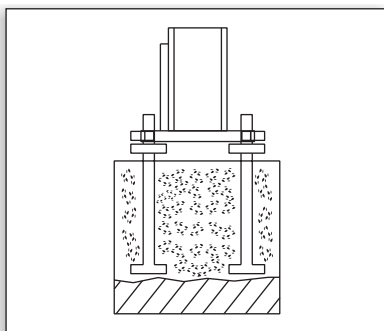

4. Make a concrete block over the bolts of about 200 x 200 mm upto the base of BASE i.e. 150mm high.

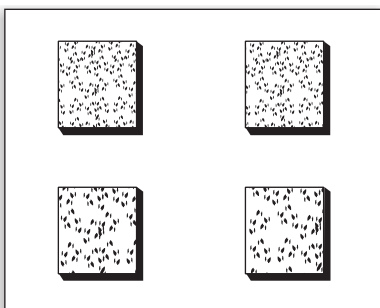

5. Prepare separate block for each BASE instead of making one big common block. For all BASES.

STRUCTURE AND SUPPORTS

ASSEMBLING OF STRUCTURE



- ① Mark the position of required fittings on all the Vertical tubes, slide them in correct sequence and lightly Tighten.

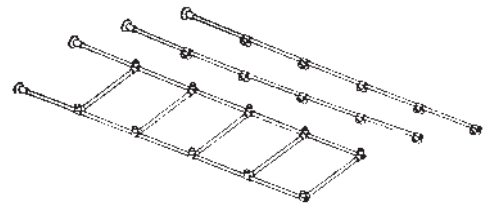

- ② Assemble one side frame of the structure by adding the cross tubes between two vertical tubes.

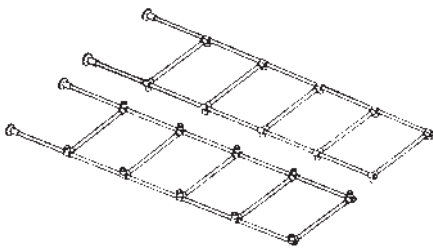

- ③ Assemble other side frame of the structure by adding the cross tubes between other two vertical tubes.

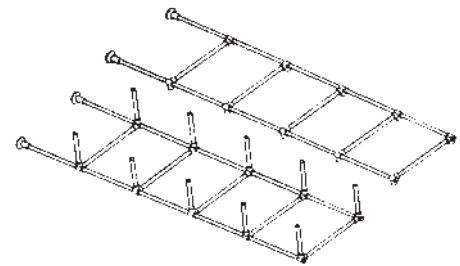

- ④ Build up the cross tubes in one side frame and Tighten lightly.

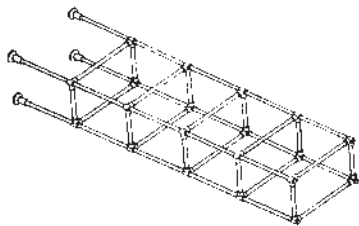

- ⑤ Add the other side frame on it and tighten all the fittings firmly.

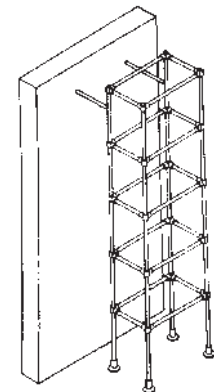

- ⑥ Hoist the structure and brace it to some existing rigid feature.

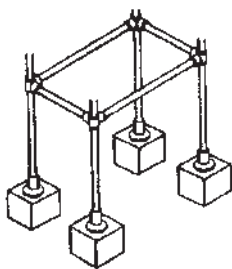

- ⑦ Grout the foundation bolts and fix the structure bases with that.

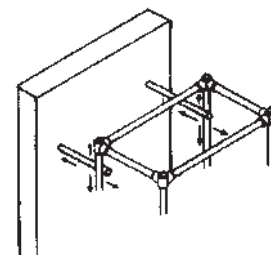

- ⑧ Adjust bracing to obtain a correct plumb in Structure.

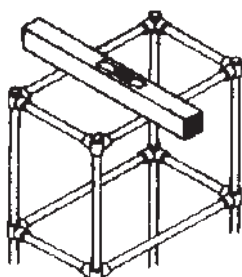

- ⑨ Adjust the horizontal frames in correct level.

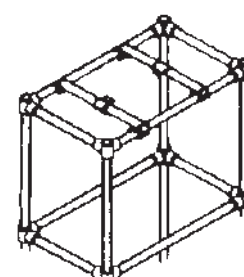

- ⑩ Assemble the support tubes at their positions.