

TECHNICAL PACKAGES



We form a combination of Chemical Engineers in the field of Process engineering and its application in the glass equipments/process packages.

DESIGN AND SUPPLY OF VARIOUS

UNITS as per client's requirement are as under:

1. Absorption systems for gases such as HCl, Cl₂, SO₂, HBr, NH₃, Br₂, NO_x etc.
2. Anhydrous HCl Gas Generation Unit by different routes viz.
 - Sulphuric Acid Route
 - Boiling Route
 - Calcium Chloride Route
 - Cyclic Route
3. HBr Gas Generator (By Boiling Route)
4. Sulphuric Acid Dilution Units.
5. Hypochlorite Manufacturing Units
6. MCA Condensation Assembly
7. Distillation - Conversion of Batch Process to Continuous Process.
8. Solvent Recovery
9. Iodine Recovery
10. Raw DCB Plant.

KNOW-HOW WITH PLANT

for the following products :

1. Bromine recovery from industrial waste / salt bittern.
2. Nitric Acid Concentration
3. Sodium Hypochlorite

TROUBLE SHOOTING

in above units as well as client's existing plant.

TECHNICAL PACKAGES

WIPING FILM EVAPORATOR

Introduction

Heat sensitive products like vitamins, hormones, enzymes or aromatic substances get adversely affected by way of material degradation due to higher temperature and residence time. This can be avoided if the reactions are carried under vacuum which allows the working temperature to be lowered, and by forming a thin film to reduce residence time, especially in case of liquids of high viscosity, or low thermal conductivity.

For these, GOEL introduces a specially designed range of Evaporators made of Borosilicate Glass. The range varies from laboratory size (80DN) to production plants (300DN).

Construction

The core of the unit is a rotating, fully corrosion resistant wiper system. This has four rows of PTFE wipers. These rows of wipers are divided into vertical segments and each wiper is mounted between two glass rods.

A liquid distributor is located above the wipers. It distributes the medium, fed in through the feed pipe uniformly around the circumference of the evaporator before the medium is finally picked up by the wiper system itself.

The Evaporator has a vapour outlet which can be connected to a descending coil condenser and a receiver.

The drive used for the wiper system is a standard geared-motor with an AC speed regulator. The wiper shaft is sealed by means of a mechanical seal. The evaporator body is constructed as a jacketed pipe. For heating, thermic fluid upto 150 C can be circulated in the jacket.

The unit is designated by the jacketed pipe size. And the capacity of the unit depends on the evaporation rate which in turn depends on the HTA available, the type of heating media, and the evaporation environment i.e. vacuum conditions.

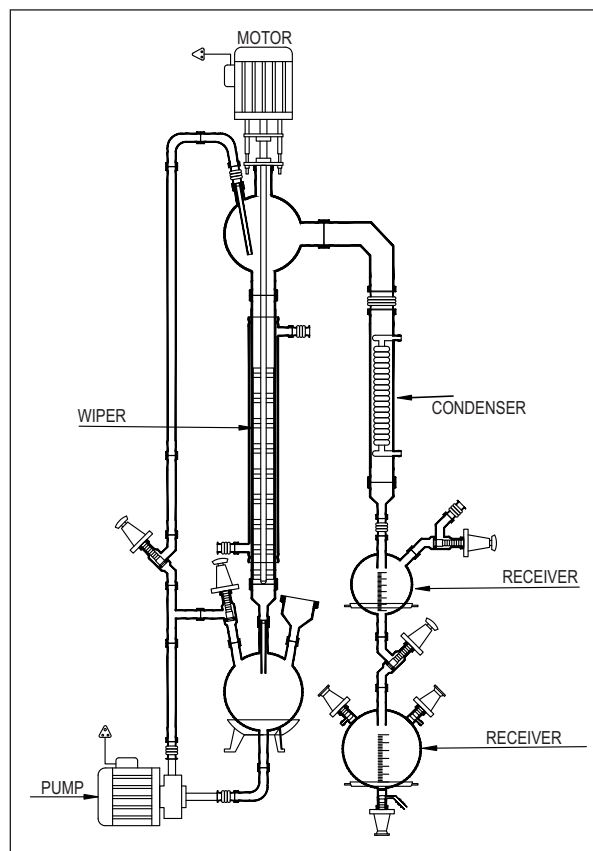

Model	Size DN (mm)	HTA (M ²)
WFE3	80	0.35
WFE4	100	0.47
WFE6	150	0.70
WFE9	225	1.06
WFE12	300	1.41



TECHNICAL PACKAGES

FALLING FILM ABSORBER

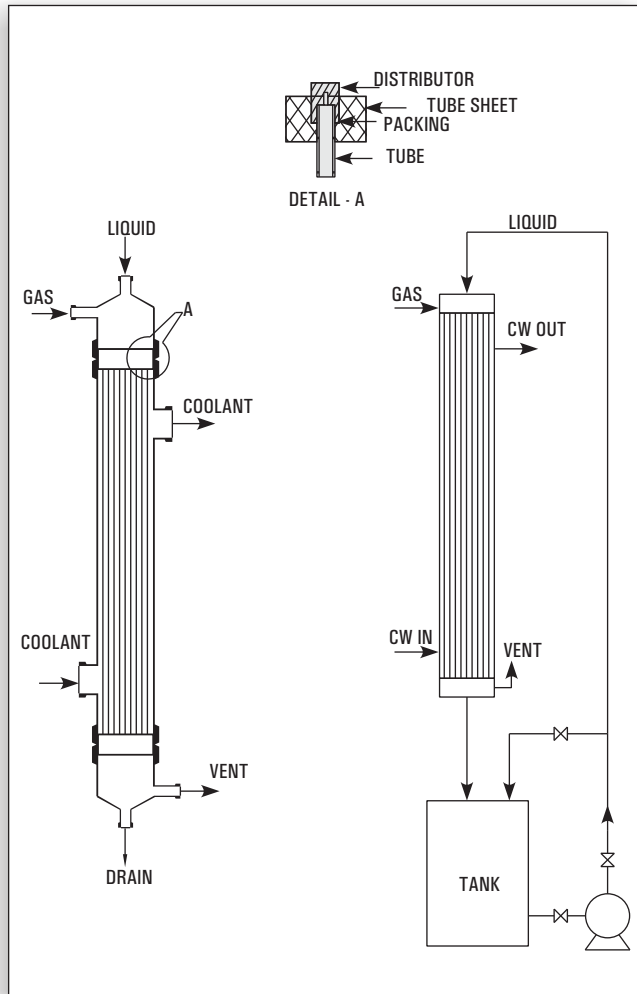

Efficient gas absorption depends on the following :

1. Intimate contact.
2. Efficient Heat Transfer.

This is achieved in a Falling Film Absorber which is essentially a shell & tube heat exchanger in which both gas to be absorbed and absorbing liquid flow concurrently downward with extraction of heat by circulation of coolant in the shell. The absorbing liquid is circulated through a tank till desired concentration is achieved. The liquid flows at such a rate that the tubes do not flow full of the liquid but instead, descends by gravity along the inner walls of the tubes as a thin film. Obviously, this produces a much greater linear velocity for a given rate flow than could be obtained if the tube flowed full.

The equipment works as a number of water cooled wetted-wall columns in parallel and each tube is provided with distribution system on top to effect uniform distribution of both liquid and gas and also formation of a thin liquid film on the inner surface of the tube.

SALIENT FEATURES

1. The heat of absorption is continuously removed. This ensures better absorption and product concentration as compared with conventional packed tower.
2. Low residence time and operating temperature ideally suited to heat sensitive materials.
3. Borosilicate glass and PTFE contact parts ensure corrosion/contamination free operation.
4. Both standard and custom built units are available.
5. Capable of operating from zero to maximum gas flow rate.
6. Ease of installation due to light weight.
7. Trouble free and consistent performance with minimal attention.
8. Wide application e.g. HCl, HBr, NH₃, SO₂, H₂S, Br₂ etc.
9. Less cost.
10. Negligible pressure drop compared to conventional columns.
11. Compact design Sleek and slender.
12. Both heat and mass transfer operations are incorporated in a single equipment.
13. Very high heat transfer coefficient as the liquid falls instead of flowing.
14. Scaling of process fluid is minimal due to high velocity and ease of cleaning by simple acid circulation.
15. Hot conditions are eliminated at all stages namely pipe, tanks and pumps etc.

LIMITATIONS

1. Not recommended for gases containing high proportion of inert (insoluble).
2. Not applicable if the gases are not highly soluble.

SPECIFICATIONS

Sr. No.	Nominal Size (mm)	Absorber Area (m ²)	No. of Tubes/ Tube OD (mm)	Max. Gas Absorption Rate (Pure HCl) * (kg/hr)	Max. Acid Prod. Rate (As 30 % HCl) (kg/hr) *	Height (m)
1.	80	1.00	4/ 20	30	100	4400
2.	100	1.76	7/ 20	60	200	4500
3.	150	4.80	19/ 20	150	500	4600
4.	225	7.80	31/ 20	250	833	4920
5.	300	15.30	61/ 20	500	1667	5050
6.	400	36.00	143/ 20	1175	3917	5300
7.	450	47.00	187/ 20	1500	5000	5700
8.	600	84.00	333/ 20	2700	9000	5800

TECHNICAL PACKAGES

SULPHURIC ACID CONCENTRATION SYSTEM

Commercial sulfuric acid is a cheap commodity and in its dilute and impure form does not have good market potential.

Disposal by neutralization with lime is associated with, problems of solid (calcium sulfate) handling and also adds to the cost.

To overcome these problems GOEL offers know-how, design engineering services of sulfuric acid concentration system in which the dilute sulfuric acid generated is reconcentrated to desired level for reuse. That is to say a twofold benefit of eliminating the disposal problem and minimizing fresh commercial acid requirement.

PROCESS DESCRIPTION

The process is extremely simple & involves concentration of dilute sulfuric acid by evaporation using steam/thermic fluid as heating media under vacuum. The dilute feed is preheated & fed to a series of evaporators in stages to achieve the concentration level. The vapors from the evaporators are condensed and drained out through barometric legs and non-condensables are removed by an ejector. The final product is cooled and drawn in the storage tank.

REQUIREMENT OF UTILITIES

The requirement of utilities viz. steam/thermic fluid, cooling water and power vary widely depending on feed rate, feed concentration and product concentration. For example for a plant having 50TPD feed containing 50% H₂SO₄ the consumption of utilities for achieving 70% concentration are given below.

1. Steam @ 6 bar(g) pressure	800 Kg/hr
2. Cooling water @ 30 °C	70 Cu M/hr
3. Power	15 KW

KEY

- 1 - PRODUCT COOLER
- 2 - FEED PREHEATER
- 3 - 1ST, STAGE EVAPORATOR
- 4 - 2ND, STAGE EVAPORATOR
- 5 - MIST ELIMINATOR
- 6 - DIRECT COOLER
- 7 - EJECTION
- 8 - SEAL POT
- C - STEAM CONDENSATE
- CWS - COOLING WATER SUPPLY
- CWR - COOLING WATER RETURN

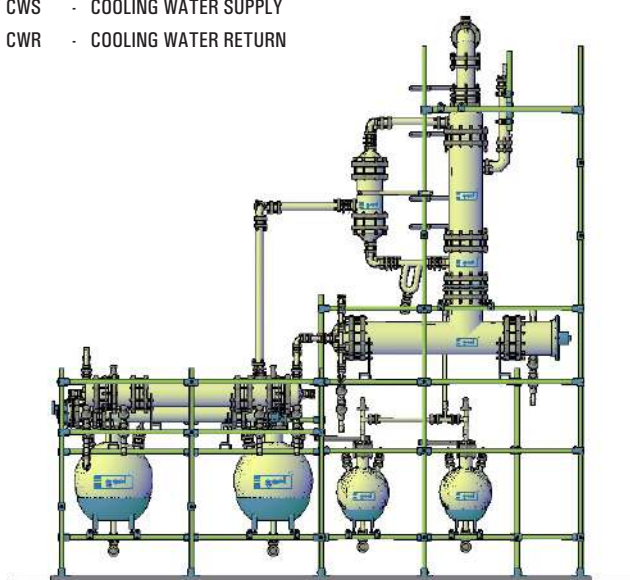
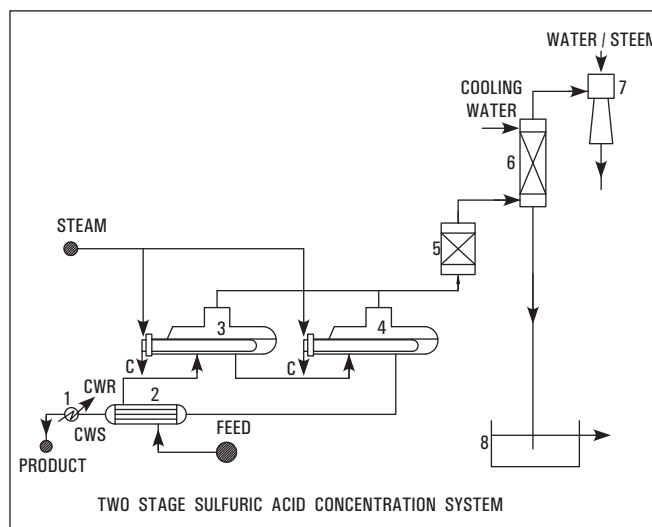

TECHNICAL PACKAGES

ANHYDROUS HCL GAS GENERATOR

Commercial Hydrochloric Acid is available in the market as 30% aqueous solution. But for certain applications e.g. bulk drug and pharmaceuticals, HCl is required in anhydrous state for critical reactions where moisture cannot be tolerated. Such users generate anhydrous HCl from commercial grade for their captive consumption.

METHOD

Several methods have been adopted by industries. But generation by Sulphuric Acid Route and Boiling Route are commonly practiced.

We offer Calcium Chloride Route also.

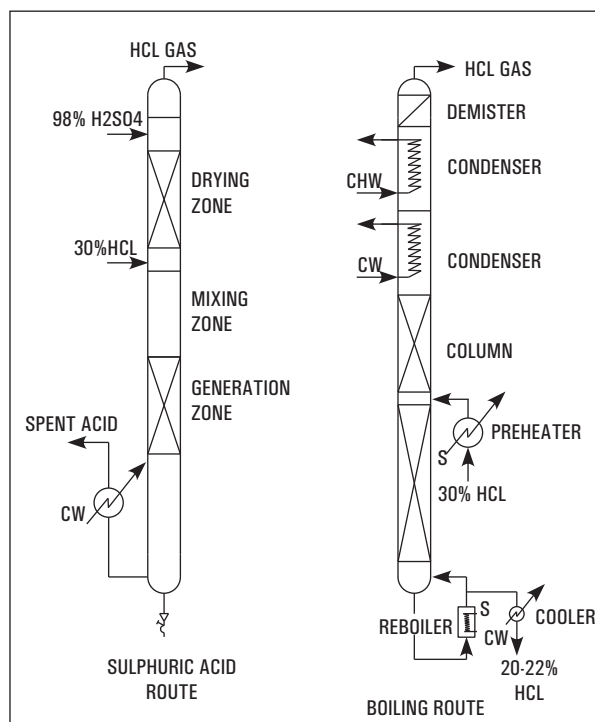
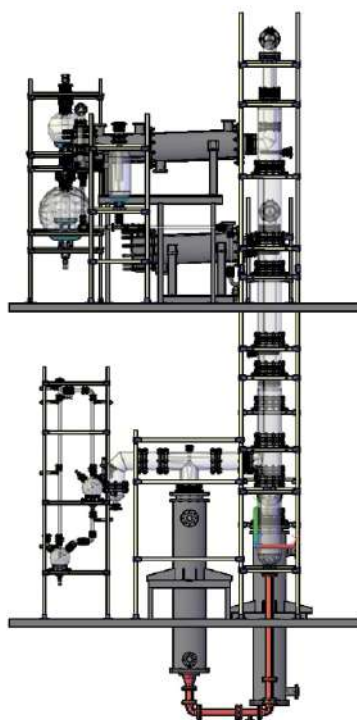

Route	Sulphuric Acid Route	Boiling Route
Working Principle	Hydrochloric acid is highly soluble in water but the solubility diminishes in presence of H ₂ SO ₄ and at 70 to 75% H ₂ SO ₄ concentration its solubility is negligible. Thus by adding (98%) commercial Sulphuric acid to commercial hydrochloric acid (30%) in proper ratio the entire HCl can be liberated in gaseous form leaving 75% H ₂ SO ₄ as spent acid.	Aqueous hydrochloric acid forms a maximum boiling point azeotrope at 110°C containing 20.24% HCl at atmospheric pressure. Thus by distilling commercial hydrochloric acid (30%) pure HCl gas can be generated and spent acid will contain over 20.24% HCl.
Process Outline	Metered quantities of commercial sulphuric acid hydrochloric acids are fed to the unit where they mix in the Mixing Zone. The gas generated forms a froth and enters the Generation Zone where while traveling through a bed gas is released which travels upwards through the Drying Zone. Here the gas comes in intimate contact with downward flow of 98% H ₂ SO ₄ . The dry gas leaving the unit passes through a rotameter. The spent liquor containing 70-75% H ₂ SO ₄ passes through the Cooling Zone before being discharged.	Metered quantity of commercial hydrochloric acid is preheated in a preheater by steam and fed to a fractionating column with steam as heating media in the reboiler. The vapours leaving the column are condensed with coolant as cooling water and chilled brine in stages. The relatively dry gas passes through a mist eliminator and then through a rotameter. The spent acid containing 22% HCl is cooled through a cooler and then discharged.
Salient Features	<ul style="list-style-type: none"> - Operational reliability the unit can be started/ stopped in seconds. - Available in wide range of capacities from 5 to 200 kg/hr of dry HCl. - Except cooling water no other utility e.g. steam chilled water etc. required. - Anhydrous gas. - Capable of operating from 25 to 120%. - Ease of installation. - Negligible pressure drop. - High efficiency 99%. 	<ul style="list-style-type: none"> - Operational reliability. - Available in wide range capacities from 5 kg/hr to 200 kg/hr of dry HCl. - Except commercial hydrochloric acid, no other raw-material is required. - Anhydrous gas. - Capable of operating from 25-100%. - Ease of installation. - Negligible pressure drop.
Indicative Raw-material & Utilities for 20 kg/hr HCl	30% HCl - 70 kg/hr 98% H ₂ SO ₄ - 170 kg/hr Cooling Water - 2 m ³ /hr	30% HCl - 200 Kg/hr Saturated Steam - 50 kg/hr Cooling Water - 3.5 m ³ /hr Chilled Brine - 4 m ³ /hr

TECHNICAL PACKAGES

ANHYDROUS HCl GAS GENERATOR - CALCIUM CHLORIDE ROUTE

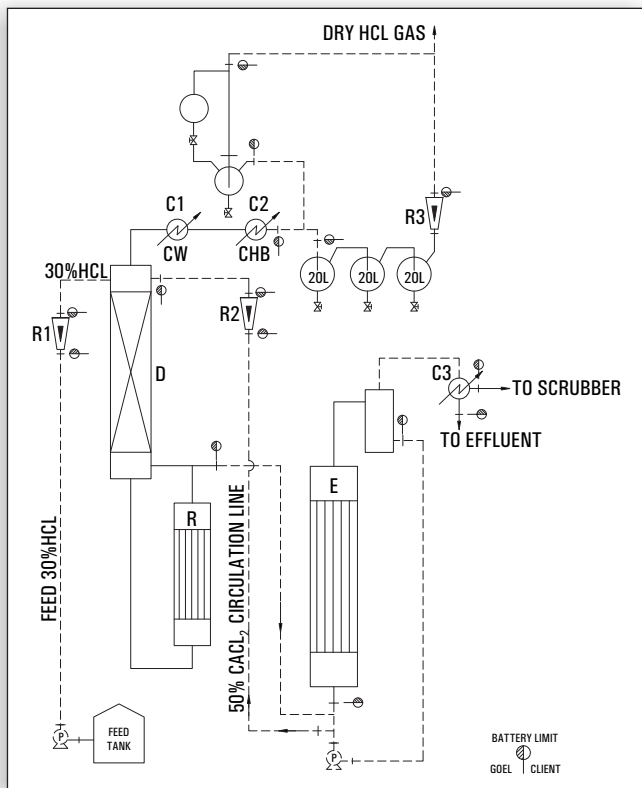

Working Principle:

Hydrochloric acid and water form a maximum boiling point azeotrope at 110°C corresponding to a concentration of 20.24%; (w/w) HCl. By adding concentrated CaCl₂ solution to commercial hydrochloric acid the azeotrope point is eliminated and the entire HCl becomes available for liberation by distillation. Anhydrous HCl gas generation through Calcium Chloride Route is the most environmental friendly technique.

Process Description:

The above principle- is achieved in practice by feeding metered quantities of commercial HCl and 50% CaCl₂-solution to a stripping column with a steam heated re-boiler at bottom. The effluent from bottom of the column is a dilute acidic calcium chloride solution which is concentrated to 50% in an evaporator and re-used. The vapor leaving is condensed stage wise with cooling water and chilled brine as coolant. The relatively dry gas passes through a mist eliminator and then through a rotameter to the point of consumption.

Raw material utility requirements:

The indicative requirements for 20 Kg/hr HCl gas generator are given below.

1. 30-32 % HCl, (Kg/hr) : 66
2. Cooling water at 30 °C (M³/hr) : 4
3. Chilled brine at -10 °C (M³/hr) : 3
4. Steam at 6 Kg/cm² (g) : 150

LEGEND

R - REBOILER

D - COLUMN

E - EVAPORATOR

C1 - PRIMARY CONDENSER

LEGEND

C2 - SECONDARY CONDENSER

R1 - FEED HCL ROTAMETER

R2 - FEED CaCl₂ ROTAMETER

R3 - DRY HCL GAS ROTAMETER

LEGEND

CW - COOLING WATER

CHB - CHILLED BRINE

C3 - CONDENSER

P - PUMP

CONTINUOUS DISTILLATION SYSTEM

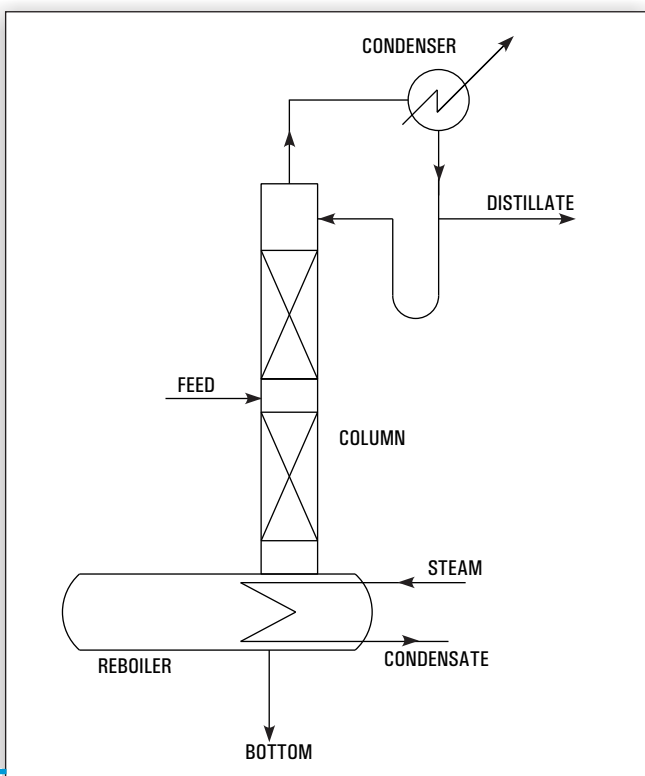

The limitations of batch distillations are naturally circumvented in continuous distillation as shown in fig.2 which is a typical fractionating unit comprising of ratification & stripping sections. Here feed is continuously fed to the column with withdrawal of top & bottom products. The process takes care on its own by simply maintaining the flow rates of feed & utilities.

However when more than two products are desired as in case of multicomponent systems additional columns are required as each column is capable of giving two products only. That is to say, for multicomponent system only one product is obtain in relatively pure form from each column. The other product containing the remaining components is fed to a subsequent column where again one product is obtained in relatively pure form. The addition of columns continue till the system becomes binary & both components are separated in the final column.

An important principle to be emphasized is that a total n-1 fractionators are required for complete separation of system of n components. Which of the two products in a column is to be obtained in relatively pure form depends on relative volatility of each component in the feed stock. For example consider a ternary solution consisting of a components A, B & C whose relative volatilities are in that order (A most volatile). In order to obtain three substances in substantially pure form either of the schemes shown in fig-3 may be used. Which of the two schemes would be used depends on the relative difficulties of separation in each method and the choice calls for finer considerations of principles of distillation. However scheme (b) is usually preferred since it requires one vaporization of substance A.

TECHNICAL PACKAGES

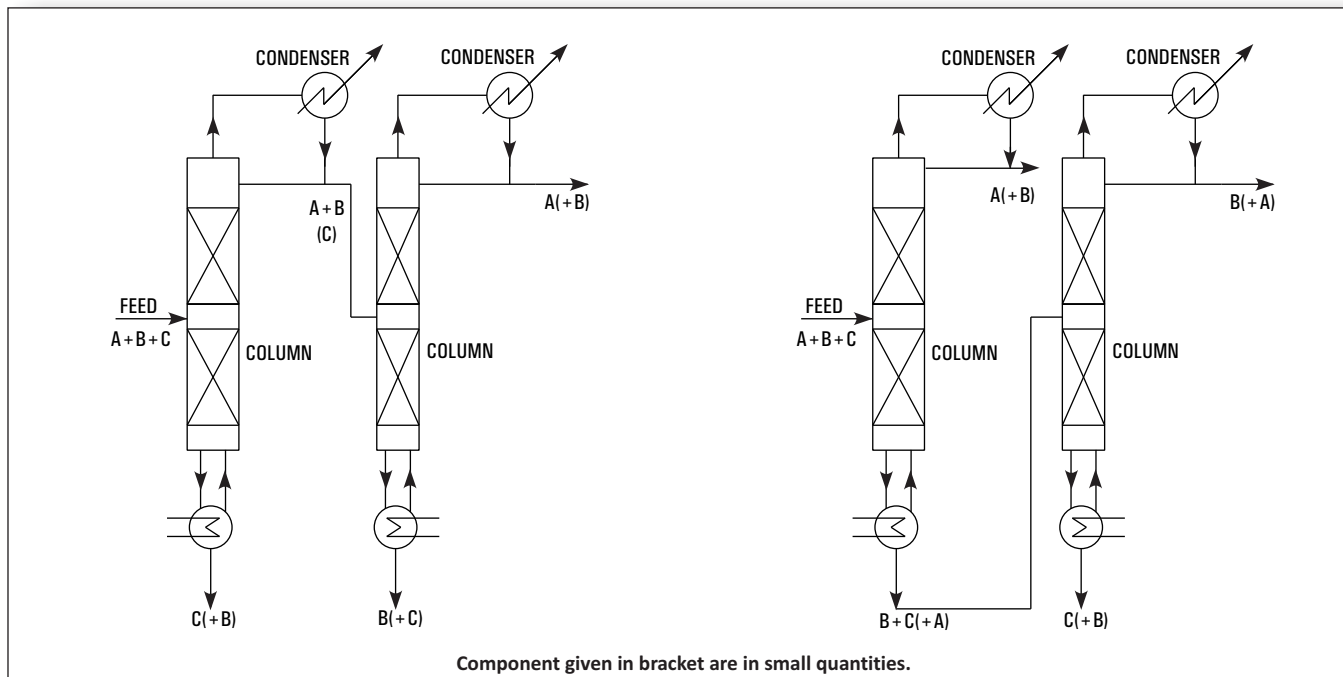

SOLVENT RECOVERY

Solvents are universally used in wide variety of industries, their use by no means being limited to the chemical industry. The choice of solvents such as xylene, acetone, butyl acetate, methanol etc. depends on the type of application and economical considerations.

In many cases, the solvent - after use - is contaminated and not in a reusable condition. Purchase of fresh solvent and disposal costs of the contaminated solvent can prove expensive operations. Therefore, it makes sound economic sense to investigate the recovery of contaminated solvents for re-use.

GOEL design and supply solvent recovery plants which are capable of recovering solvents from a few kg/day to many tons/day.

Applications:

1. GOEL Solvent Recovery Units are carefully designed to cater the specific requirement for each duty for wide range of solvents.
2. Continuous Distillation Units have distinct advantages, such as
 - 2.1. Ease of Operation due to steady state working.
 - 2.2. Economical design as each equipment viz. column, condenser reboiler is designed for uniform and steady-load.
 - 2.3. Uniform product quality,
 - 2.4. Uniform & low consumption of utilities.
 - 2.5. Higher productivity as down time for start-up, emptying etc. is eliminated.

The outline flow-sheet of the plan is shown in Figure. Regulated quantity of feed is fed to a distillation column from an overhead vessel. The overhead vessel is provided with a vent condenser with chilled water circulation to arrest loss of acetone vapor. The reboiler at the bottom of column in this case was a steam heated oil-bath. The vapors from top of the column pass through primary and secondary condensers with cooling water and chilled water circulation. The condensate is partially refluxed and balance continuously drawn out and collected in receiver provided with a vent condenser. The residue from the reboiler is continuously drained out.

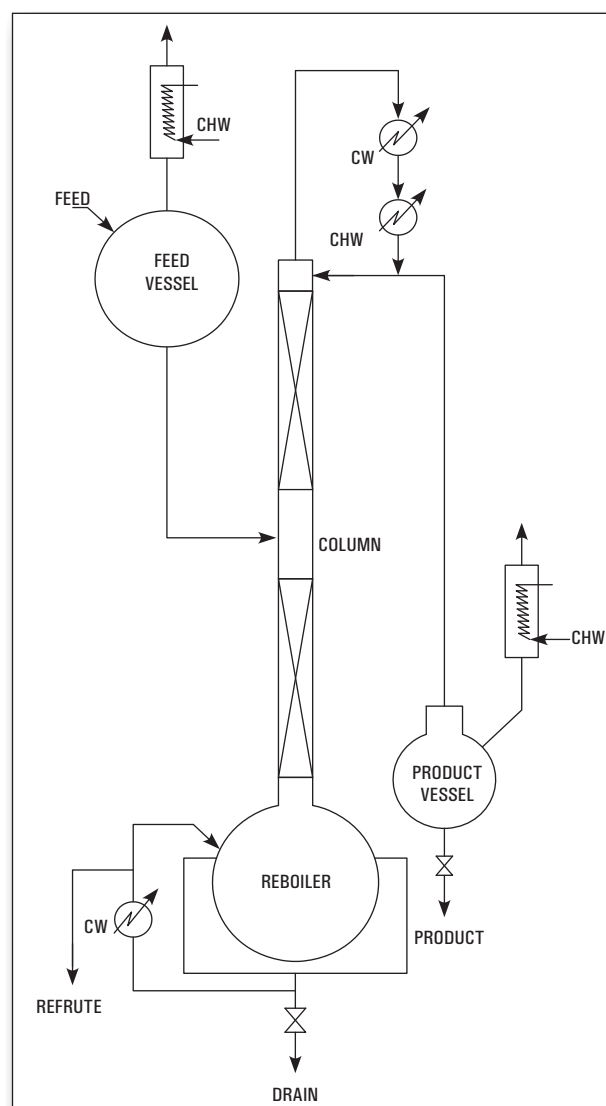

TECHNICAL PACKAGES

ROTATING DISC EXTRACTION COLUMN

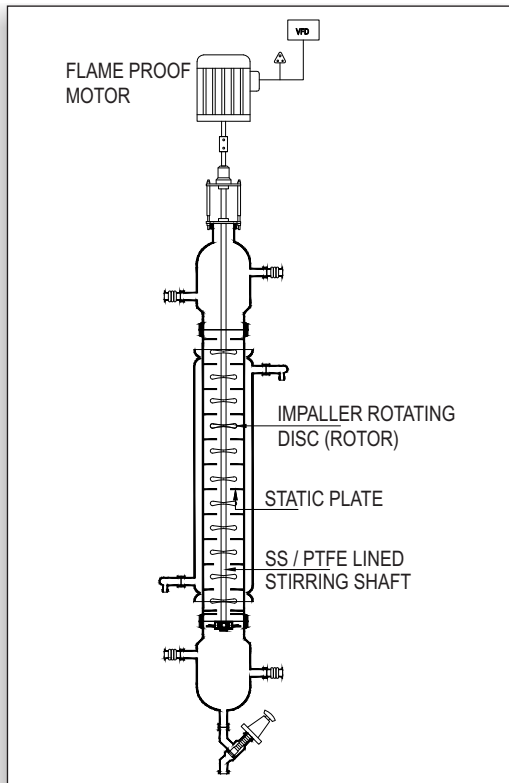

Introduction

Separation will be carried out normally with the help of distillation but when it is not feasible by distillation or ineffective liquid-liquid extraction is one of the process to consider. There few mixtures are having close boiling points components or heat sensitive components which can not withstand the temperature of distillation, even under vacuum may often be separated from impurities by extraction which utilize the chemical properties like specific gravity, solubility etc. instead of vapour pressure differences.

Separations by liquid-liquid extraction can be defined as the selective removal of one or more components either from a homogenous liquid mixture or from a solution, using a second liquid or solvent, which is partially or wholly immiscible with the first.

Construction

The core of the unit is a rotating disc with varied no of stages between 1 m to 2 m height. The RDC blade can be made of PTFE or SS 304 or SS 316 depending on the customer requirement.

The system can be supplied with or without dosing pump and two feed vessels as well as two receivers. The drive used for the rotation of the disc is a standard geared-motor with an AC speed regulator. The agitator shaft is sealed by means of a mechanical seal.

The outer column can be constructed as a jacketed pipe or without jacket as per the customer requirement. The unit is designated by the diameter of the extraction column and no. of stages as per the customer specification depends on the flowrates and properties of the chemical used.

Model	Size	DN (mm)Hight
RDC3	80	2.0
RDC4	100	2.0
RDC6	150	2.0
RDC9	225	2.0
RDC12	300	2.0
RDC16	400	2.0

PRECIOUS METAL REFINING

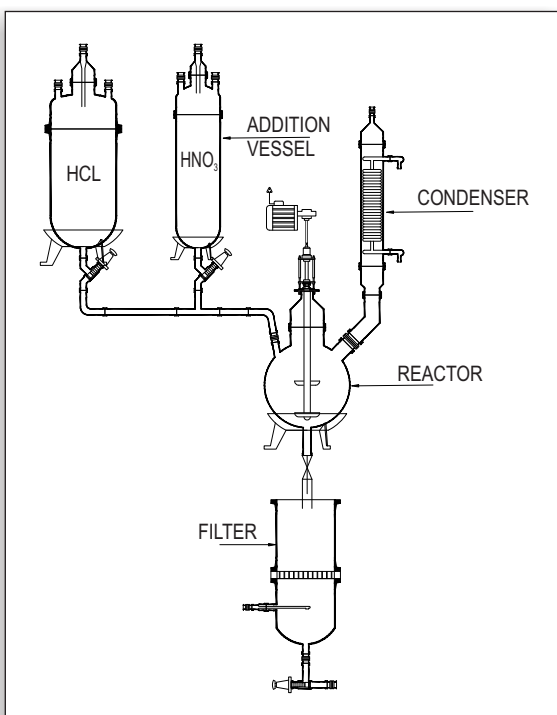

Borosilicate glass is inert to almost all materials. Due to which it is now widely used in Precious Metal Refining Industry. Borosilicate Glass is the only material which doesn't absorb precious metals. Its transparency allows ease of visualization & smooth surface allows ease of cleaning.

We have supplied various capacity glass assemblies in precious metal refinery for Aqua Regia solution. Our Glass Container/Vessel are also used as dissolution, precipitator and separator for Gold /silver/ platinum recovery with Aqua Regia / Hydrazine solution.

Scrubbing Unit :The fumes generated by Aqua Regia in a gold refining process are toxic. We design & offer suitable capacity Glass Scrubber Unit for removal of NOX Fumes.

Filer Unit :We also offer Glass Filter Unit on wheels for removing of precious metal from the Aqua Regia solution.

Nitric Acid Boiling Apparatus :Nitric Acid Boiling Apparatus with condenser for Laboratory testing is also available with us.

Sampling Tubes :Vacuum Tubes (VPT 111) for removal of samples from the batch are also manufactured by us.

TECHNICAL PACKAGES

NITRIC ACID PURIFICATION SYSTEM



The process to purify industrial/technical grade nitric acid involves a single stage distillation to leave non-volatile impurities in the still bottoms. 69% – 70% concentrated nitric fluid is delivered by means of a metering pump from a storage tank into the glass still which is equipped with Electrically heated Oil Bath. The acid vapors flow through a mist removing packed section to the Glass condenser. Depending on the desired concentration high pure water can be added as a diluent to the condensed product before entering the bleach column. Clean air is introduced at the base of the bleacher. Air and oxides of nitrogen are vented through a condenser to a scrubber. Entrained nitric acid is not returned to the bleaching column but collected separately. Removing of all NO_x out of electronic grade nitric acid.

Design Basis & Requirement of Utilities :

Capacity	40	kg/hr
Commercial grade Nitric Acid - 69-70%	44	kg/hr
Electric Heater	48	kw
Cooling Water @ 7 deg. C*	4-5	Cu.M/hr
Space Requirement	3 x 3 x 8 m	

Size Available 5 kg/hr to 500 kg/hr

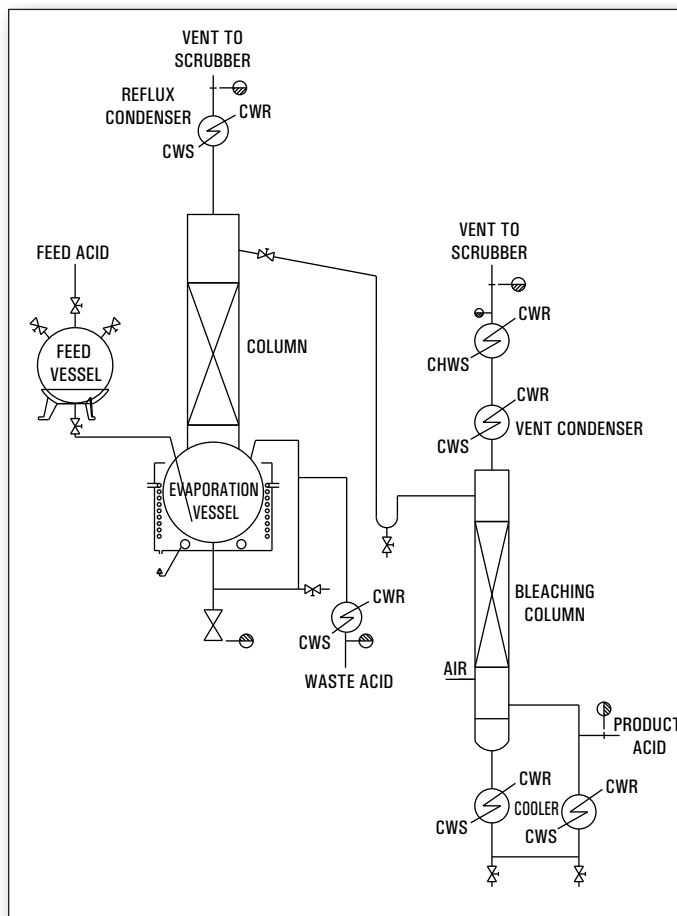

TECHNICAL PACKAGES

HCL PURIFICATION SYSTEM

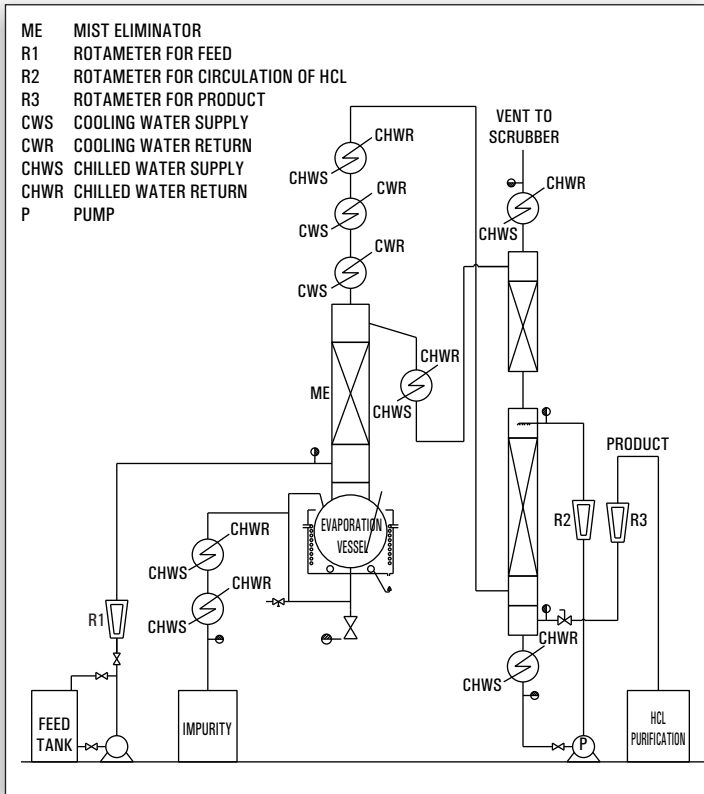

Commercial Grade Acid (30% HCL) is feed to the Reboiler through Flow meter. The feed will be heated in Re-Boiler by heating media to evaporate the 20-22% HCL. The 20-22% HCL+ Water Vapour generated will be condensed in Top Cooler with Cooling water & chilled water. The gas leaving the top will be of pure HCL gas will fed to the scrubber wherein it will be scrub further with condensed Azeotropic solution or with fresh process water to make ultrapure HCL.

There are various options to make ultrapure HCL Depending on following factor : 1. feed quality 2. Effluent generation 3. Capital investment etc...

Goel offers various solution for HCL purification based on customer need.

Sr. No.	Feed 30% HCl (w/w)	Product 36-37% HCl	Cooling Water @32 deg. C	Chilled Water @8 deg. C	Power
	Kg/hr	Kg/hr	Cu. m. / hr *	Cu. m. / hr *	KWH (Max.)
1	15	12.5	8-10	5-6	10

